

Air & Climate Solutions

Installation Manual

Contact cooling ceiling system for
gypsum board ceilings KKS-4/GK

Durrer-technik

Kranz

Safety

This manual provides essential information for the safe handling and installation of the Krantz contact cooling ceiling system for gypsum board ceilings, *KKS-4/GK*.

1. Safety

Read this manual carefully. Make sure that you have understood all the contents of these instructions before you start installation. Following the described work steps and safety guidelines is essential to ensure the functionality and safety of the products mentioned. Act with caution. Also observe the locally applicable accident prevention regulations and the general safety standards to avoid accidents, personal injury, and damage to property.

1.1 Symbols and safety instructions

Safety instructions in this manual are identified by symbols and signal words that indicate the respective hazard potential.

	WARNING
This symbol and signal word combination indicates a potentially hazardous situation that can lead to death or serious injury if not avoided.	

	CAUTION
This symbol and signal word combination indicates a potentially hazardous situation that, if not avoided, may result in minor or moderate injury.	

	NOTE
This combination of symbol and signal word indicates a potentially hazardous situation that can lead to material damage if not avoided.	

	INFORMATION
This combination of symbol and signal word highlights additional information that is helpful for understanding or carrying out the work but is not safety-related.	

	ENVIRONMENTAL PROTECTION
This symbol and signal word combination indicates possible environmental damage.	

1.2 Qualification of the staff

Only persons who can reliably carry out the work are authorized to work with the Krantz contact cooling ceiling system *KKS-4/GK*. Persons with impaired reactions, e.g. due to medication, alcohol or drugs, are not permitted to carry out any tasks. Trained specialist personnel are required to carry out the following activities:

- Transport
- Installation
- Commissioning
- Repair



1.3 Intended use

As a contact cooling ceiling system for installation in suspended ceiling structures, the Krantz *KKS-4/GK* is intended exclusively for indoor use. The use of the product must comply with the specifications defined in the Technical Selection. Any other or extended use is considered improper.

	NOTE
Material damage due to misuse	
Improper use of the product can lead to damage to the product! Do not use the product in the following rooms or areas:	
<ul style="list-style-type: none">▪ Outdoors▪ Damp rooms▪ Rooms with aggressive or dusty air	

1.4 Personal protective equipment

Wear protective equipment when working with the product to minimize health hazards. Additionally, observe and use the prescribed protective equipment for the construction site on which the Krantz contact cooling ceiling system *KKS-4/GK* is installed. The required personal protective equipment includes:

-  **Protective gloves**
Protective gloves are used to shield the hands from friction, abrasions, punctures or deeper injuries, as well as from contact with hot surfaces.
-  **Safety shoes**
Safety shoes protect the feet from crushing, falling objects, and slipping on slick surfaces.
-  **Industrial safety helmet**
The industrial safety helmet protects the head from falling objects, swinging loads and from bumping into fixed objects.

2. Structural Design

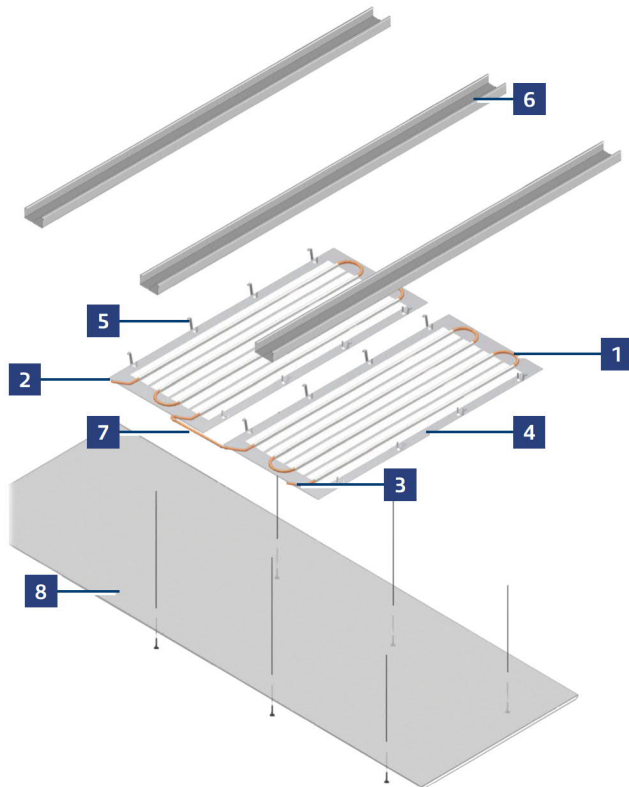

Structural design exemplified by two hydraulically interconnected KKS-4/GK elements for unperforated gypsum board panels.

Each KKS-4/GK element consists of *serpentine pipework made from copper tube* ($\varnothing 12 \times 0.5 \text{ mm}$) **1** with *connection ends* **1** for *chilled-water inflow* **2** and *outflow* **3**, an *aluminium heat conducting plate* **4** with formed pipe saddles for receiving the copper serpentine, and *suspensions* **5** for hooking into the ceiling suspension structure made of *furring channels (CD profiles)* **6**. Installation of the KKS-4/GK elements is based on the project-specific ceiling layout provided by Krantz, which defines the position and orientation of the cooling elements. Hydraulic coupling of adjacent KKS-4/GK elements is carried out in accordance with the layout using the *specified connecting components* **7** (copper connecting bend or flexible connecting hose).

After installation, the KKS-4/GK elements can be hydraulically connected and subjected to a pressure test. The subsequent lining with *gypsum board panels* **8** is carried out by screw-fixing them to the furring channels of the CD substructure. Final surface treatments of the gypsum boards—such as jointing, sanding and painting—can then be performed as usual.

Information on the function and dimensions of the product can be found in the Technical Selection on our website (www.krantz.de).

2.1 Product variants

Depending on the variant, the KKS-4/GK contact cooling ceiling system is suitable for use with perforated or unperforated gypsum board panels.

KKS-4/GK/G elements for perforated gypsum board panels

- Nominal length: 500 to 2500 mm
- Nominal width: 250 mm



KKS-4/GK/U elements for unperforated gypsum board panels

- Nominal length: 500 to 2500 mm
- Nominal width: 420 mm



Structural Design, Delivery and Transport

2.2 Suspension



Hook-in suspension element
Supplied component for suspending the KKS-4/GK elements in the CD profiles of the fine-grate structure.

i	INFORMATION
The component shown is for illustration purposes. The actual component supplied may differ in form and design.	

2.3 Connections and interconnections

As gypsum board ceilings are not accessible for inspection, we recommend professionally installed copper pipework with press fittings and flexible hoses.



Copper connecting bend with press fittings
Krantz-recommended component for interconnecting two adjacent KKS-4/GK elements at the standard spacing; factory-made to the required spacing and fitted with Viega press fittings (press contour V). Supplied on request.



Flexible connecting hose with press fittings
Krantz-recommended component for interconnections between KKS-4/GK elements outside the standard spacing and for the building-side connection to the heating/chilled-water system. Stainless-steel braid (AISI 304), oxygen-diffusion-tight to DIN 4726, with an extremely smooth inner surface for reduced pipework pressure losses; fitted with Viega press fittings (press contour V). Supplied on request.

i	INFORMATION
The components shown are for illustration purposes. The components actually used may differ in form and design.	

3. Delivery and Transport

Check the delivery immediately upon receipt to ensure that it is complete and undamaged. Compare the contents with the delivery bill and ensure that all parts are present and undamaged. Report any discrepancies or damage to our customer service immediately.

	CAUTION
Risk of injury due to improper handling	
The weight of transport packaging and products can cause injuries if not lifted or carried correctly.	
<ul style="list-style-type: none"> ▪ Avoid improper lifting or carrying techniques to prevent injuries. ▪ If necessary, use aids or support to minimize the risk of accidents. 	

	CAUTION
Risk of injury from sharp edges, pointed corners, and thin-walled sheet metal parts	
Both the packaging and the products themselves may have sharp edges that could cause cuts or injuries.	
<ul style="list-style-type: none"> ▪ Handle the delivery with care when unpacking. ▪ Wear protective gloves and safety shoes 	

	CAUTION
Safety risk due to damaged or incomplete products	
Damaged or incomplete products can lead to dangerous situations.	
<ul style="list-style-type: none"> ▪ Strictly follow the instructions and guidelines in the installation manual. ▪ Never install damaged or incomplete products. 	

	ENVIRONMENTAL PROTECTION
Disposal of the packaging material	
<ul style="list-style-type: none"> ▪ Separate the packaging waste (e.g. cardboard, plastic film) and dispose of the different materials according to local recycling regulations. ▪ Take packaging materials that cannot be disposed of with household waste to the appropriate collection points or recycling centers. 	

4. Required Preparatory Works

The following site-provided preparatory works are prerequisites and must be completed before installation of the *KKS-4/GK* contact cooling ceiling system:

- Provision of a suspended ceiling suspension structure in accordance with recognised drywall specifications
- Levelling of the channels
- Application of thermal insulation (optional)
- Ensuring sufficient load-bearing capacity of the suspension structure, suitable for hangers for loads exceeding 27 kg/m²
- Provision of the required hydraulic connections for chilled-water supply and return

The suspension structure must be rigid and executed as an anti-lift double-channel suspension structure consisting of main channels (primary load-bearing members) and furring channels (secondary members for fixing the gypsum board lining).

	NOTE
Site-provided preparatory works	
The preparatory works described in this chapter are site-provided prerequisites for the safe installation of Krantz contact cooling ceiling systems. The standard installation situation shown may differ from actual site conditions. All materials required for the ceiling suspension structure must be provided on site by others. The steps described must be carried out in accordance with recognised drywall specifications and the relevant standards. Responsibility for this lies with the contractor carrying out the works.	

1. Installation of the main channels

Align the main channels with the structural soffit in accordance with the reflected ceiling plan.



2. Installation of the furring channels

Install the furring channels perpendicular to the main channels and secure them with cross-connectors. The required spacing between furring channels is specified in the Technical Selection of the *KKS-4/GK* contact cooling ceiling system.



	INFORMATION
Integrating building services such as luminaires, air diffusers or loudspeakers into gypsum board cooling ceilings is straightforward. These are preferably positioned in the passive areas between the individual <i>KKS-4/GK</i> modules.	

3. Application of insulation (optional)

Thermal insulation on the backside is generally recommended for the intended active areas.





4. This completes the site-provided preparatory works.

Installation of KKS-4/GK Elements

5. Installation of KKS-4/GK Elements

Once the preparatory works described in Chapter 4 have been completed, installation of the *KKS-4/GK* contact cooling ceiling system proper can begin. This includes fitting the suspensions to the individual *KKS-4/GK* elements, hooking the elements into the ceiling suspension structure, and making the hydraulic connections in accordance with the project-specific ceiling layout.

	CAUTION
Risk of injury from sharp edges, corners and thin-walled sheet-metal parts	
Product components may have sharp edges that can cause cuts or other injuries.	
<ul style="list-style-type: none">Proceed with care during installation.Wear protective gloves and safety footwear.	

	WARNING
Risk from falling parts	
Incorrect installation of <i>KKS-4/GK</i> elements may result in falling parts and cause serious injury.	
<ul style="list-style-type: none">Proceed with due care during installation.Wear a safety helmet during installation.After installation, carefully check all fixings to ensure safe operation.	

5.1 Fitting the suspensions

To fit the hook-in suspensions to the *KKS-4/GK* element, proceed as follows:

1. Place the *KKS-4/GK* element on a clean, soft surface to avoid damaging the aluminium heat conducting plate.
2. Sheet-metal tabs are arranged around the top side of the heat conducting plate to receive the suspensions.



Provide one suspension at each tab and ensure a sufficient number are available:

- For *KKS-4/GK* elements of nominal length 500–1100 mm, use four suspensions per element.
- For *KKS-4/GK* elements of nominal length 1200–1600 mm, use six suspensions per element.
- For *KKS-4/GK* elements of nominal length 1700–2500 mm, use eight suspensions per element.

3. Insert all suspensions into the designated tabs.

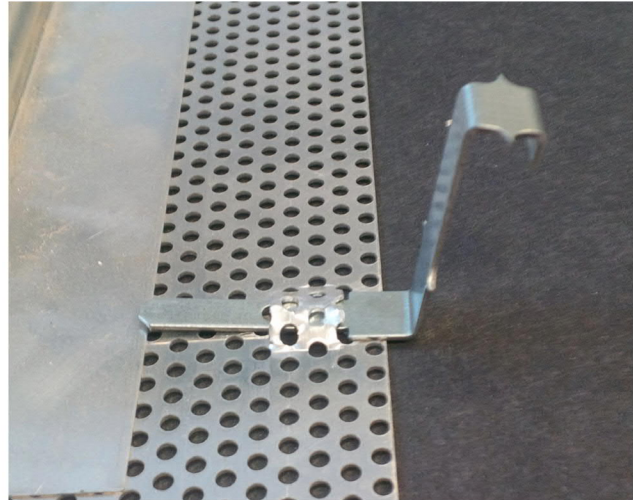

Ensure the abutting edge of each suspension sits flush against the outside of the tab.

4. Manually bend the portion of the suspension located behind the tab upwards by approximately 90° to ensure a secure connection between the suspension and the heat conducting plate.



5. Finally, check the alignment and seating of all suspensions.

Installation of KKS-4/GK Elements

5.2 Hooking in the KKS-4/GK elements

After fitting the suspensions, proceed as follows:

1. Study the project-specific ceiling layout.



The layout contains all information required for installation, including the length, position and orientation of the supplied KKS-4/GK elements.

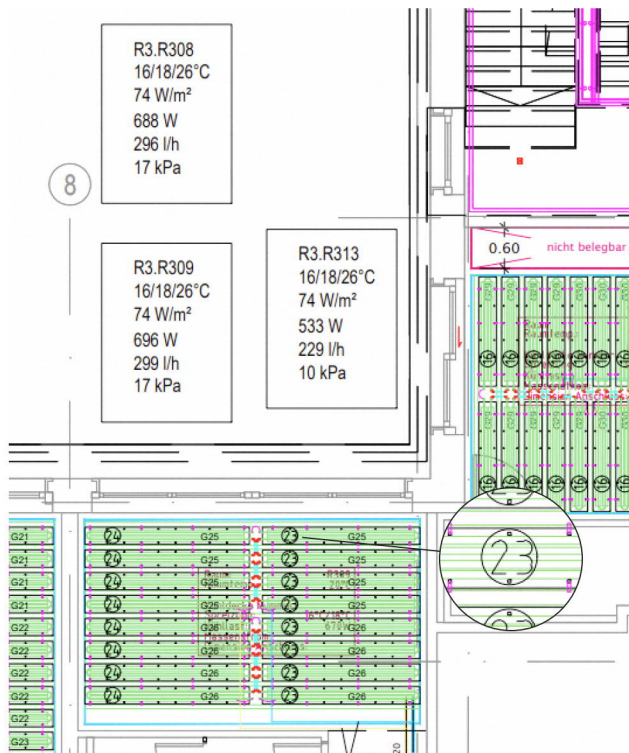

Each KKS-4/GK element is labelled with a circled length code indicating the nominal length in decimetres. Accordingly, the length code 23 highlighted in the illustrated example denotes an element with a nominal length of 2300 mm.

2. Align the elements in accordance with the layout.

Pay close attention to the specified position and orientation of the elements. Ensure that the connection ends are correctly oriented. Verify that the elements are KKS-4/GK elements of the nominal lengths specified in the ceiling layout.

3. Hook the KKS-4/GK element into the furring channels.



Ensure that all suspensions attached to the heat conducting plate properly engage with the furring channels.

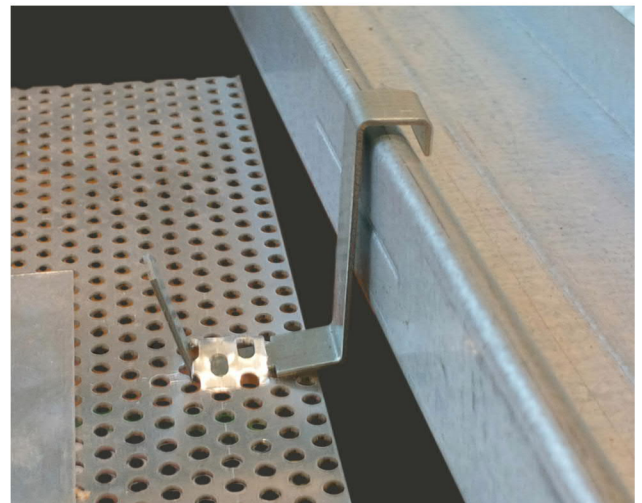

Installation of KKS-4/GK Elements

4. Check the positioning and suspension depth of the *KKS-4/GK* element relative to the furring channels.



The *KKS-4/GK* element is correctly seated when its underside is 5–7 mm below the plane of the ceiling profiles.

	NOTE
Ensure that the elements are correctly hooked in before proceeding with installation.	
Correct positioning of the <i>KKS-4/GK</i> elements is essential for the smooth execution of all subsequent installation steps.	

5. The *KKS-4/GK* element can now be connected to the pipework.

5.3 Pipework

Once all *KKS-4/GK* elements have been hooked in, the hydraulic interconnections can be made. For the hydraulic coupling of the elements using the Krantz-recommended connecting components, which are available on request, proceed as follows:

1. Study the project-specific ceiling layout.

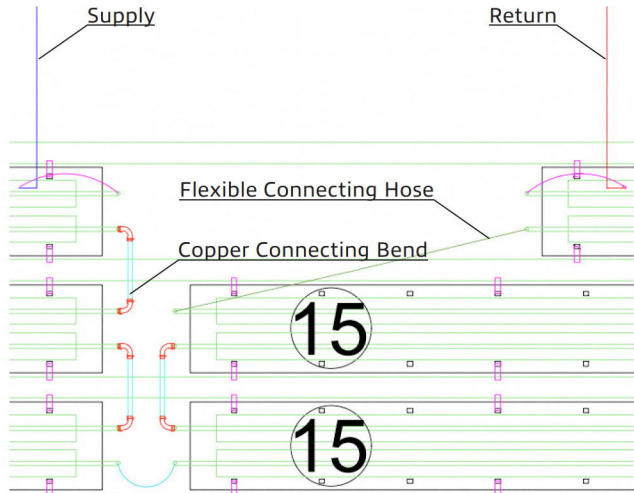

The layout contains all information required for the pipework of the *KKS-4/GK* elements:

- For the hydraulic interconnection of parallel *KKS-4/GK* elements with connection ends at the standard spacing, prefabricated copper connecting bends are used. These connecting bends are clearly indicated in the ceiling layout.
- All other hydraulic connections are made using flexible connecting hoses. In the ceiling layout, these are shown by finely drawn lines in different colours.
- The colour code of each connection indicates the length of the flexible connecting hose to be used.

Color code* – flexible connecting hoses

800 mm	
1000 mm	
1200 mm	
1500 mm	
1800 mm	

* The project-specific colour code may vary.

Installation of KKS-4/GK Elements

2. Use the connecting bends supplied with the consignment to hydraulically interconnect all connection ends at the standard spacing, as specified in the ceiling layout.

The connecting bends supplied consist of prefabricated copper tube segments fitted on both sides with press fittings mounted at right angles. Slide the fittings onto the connection ends of two adjacent *KKS-4/GK* elements up to the specified insertion depth. Before pressing, visually verify that the full insertion depth has been achieved.

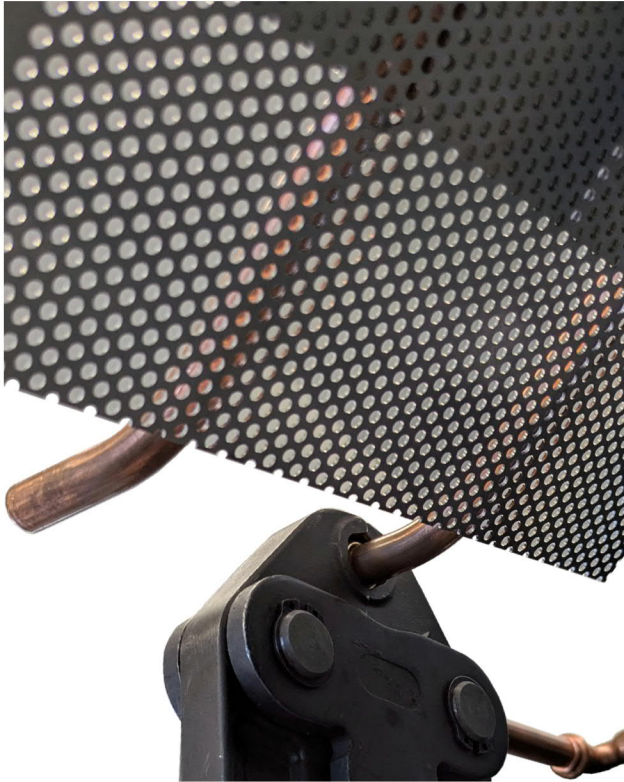

For the right-angle press fittings, Viega press fittings (press contour V) are used. Press them with a pressing jaw suitable for 12 mm copper tube.

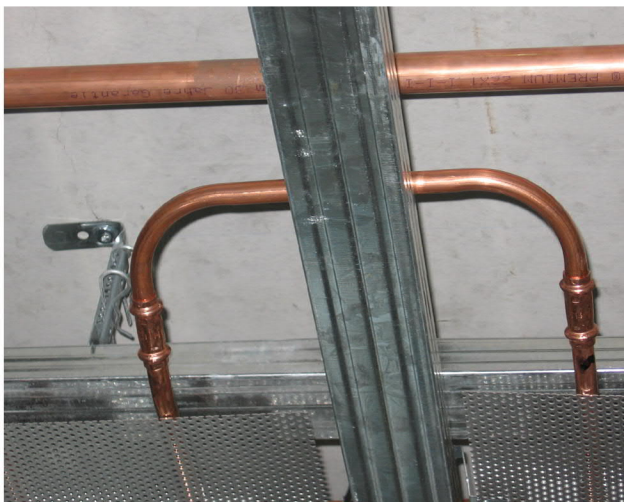

3. Use the flexible connecting hoses supplied with the consignment to hydraulically interconnect all other connection ends as specified in the ceiling layout.

Opposed or offset *KKS-4/GK* elements are coupled using flexible connecting hoses. The connecting hoses are pressure-resistant and flexible, and are fitted with press fittings at both ends. Push the fittings onto the connection ends of the elements to be interconnected up to the specified insertion depth. Before pressing, visually verify that the full insertion depth has been achieved.

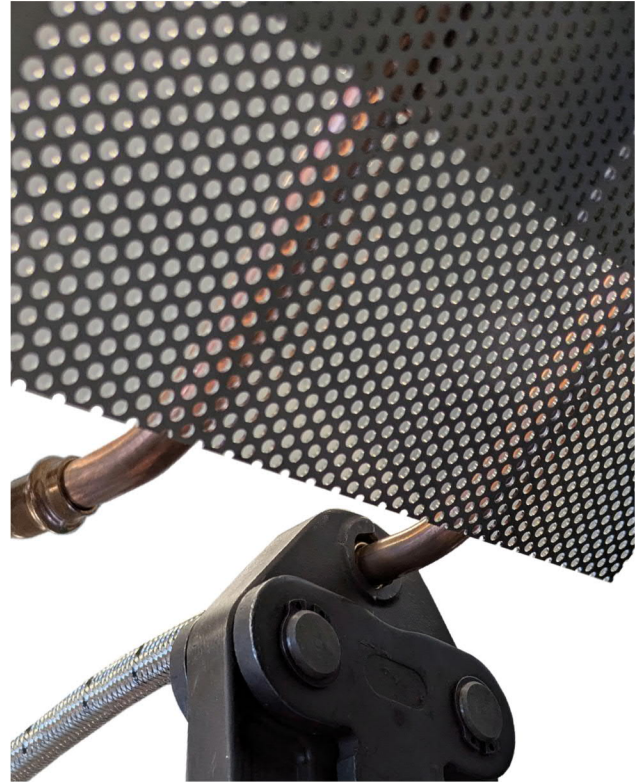

Here too, Viega press fittings (press contour V) are used and must be pressed with a pressing jaw suitable for 12 mm copper tube.



Installation of KKS-4/GK Elements, Site-Provided Finishing Works

	NOTE
Execution of press connections	
All pressing operations must be carried out in strict accordance with the manufacturer's specifications for the press system used, including all associated tools, to ensure a permanently tight and form-fit connection.	

4. Use the flexible connecting hoses supplied with the consignment also for the building-side connection to supply and return.



5. The cooling ceiling system can now be tested for function and leak-tightness in accordance with: *

- **DIN 18380**
Pressure test and leak-tightness test
- **DIN EN 805**
Pressure testing of pipelines in water supply systems; test pressure to the nominal pressure class
- **DIN EN 12266-1**
Leak-tightness testing of valves and fittings
- **DIN EN 14240**
Cooling output testing and assessment

	NOTE
Requirements for test and operating water	
For pressure and functional testing as well as for filling the cooling ceiling system, use only water in accordance with VDI 2035 (suitable fill and make-up water). The use of unsuitable water can lead to corrosion and deposits.	

6. Site-Provided Finishing Works

After installation and testing of the *KKS-4/GK* contact cooling ceiling system, the following works must be carried out on site by the drywall contractor:

- Screw-fixing the gypsum board panels to the furring channels.
- Jointing of the seams, sanding, and surface preparation for subsequent painting works.

	NOTE
Site-provided finishing works	
The works described in this chapter are drywall trade services and are not part of the product installation. The standard installation situation shown may differ from actual site conditions. Responsibility for compliance with the relevant standards and regulations lies with the contractor carrying out the works.	

	NOTE
Selection of suitable gypsum boards	
For efficient heat transfer, the use of gypsum board panels with enhanced thermal conductivity (e.g. Knauf Thermoboard) is recommended. Selection of the appropriate lining is the responsibility of the client.	

	NOTE
Manufacturers' installation guidelines	
Follow the installation guidelines of the respective board manufacturer.	
<ul style="list-style-type: none"> ▪ Use suitable screws and fixings as recommended. ▪ Ensure adequate load-bearing capacity of the gypsum boards. 	

1. With correctly installed and connected *KKS-4/GK* elements, the distance between the undersides of the elements and the ceiling plane is 5 to 7 mm.



* The standards listed are not intended to be exhaustive.

Site-Provided Finishing Works

2. Using a drywall panel lift, the gypsum board panel is raised to the required position and aligned.

In this process, the *KKS-4/GK* element is lifted by the lining. Full-surface contact between the heat conducting plate and the gypsum board panel is essential to ensure optimal thermal transfer during subsequent system operation and efficient removal of room heat.



3. The positioned gypsum board panels must be fixed to the CD profiles of the furring channel structure using self-tapping screws.



4. Once lining is complete, the ceiling is ready for further surface works (jointing, sanding and painting).

5. Inspection and acceptance of the gypsum board ceiling shall be carried out in accordance with the relevant standards.



Maintenance and Cleaning, Recycling

7. Maintenance and Cleaning

The Krantz *KKS-4/GK* cooling ceiling system is completely maintenance-free. After product installation and the site-provided finishing works, no routine inspections or interventions are required. Work on the construction is necessary only in the event of a fault or building alterations and may be carried out exclusively by qualified personnel.

	NOTE
Requirements for operating water	
For ongoing operation of the cooling ceiling system, ensure that only water in accordance with VDI 2035 (suitable fill and make-up water) is used. Unsuitable water can lead to corrosion and deposits.	

	NOTE
Procedure in the event of ceiling damage or leaks	
If the ceiling is damaged or leaks occur, the gypsum board ceiling must not be opened by unauthorised persons. Repairs to the cooling ceiling system must be carried out exclusively by qualified personnel. Unauthorised interventions can cause damage to the cooling ceiling system and to the building structure.	

8. Recycling

Our products consist of valuable materials which should be recycled at the end of their service life when replacement is necessary. The Krantz *KKS-4/GK* contact cooling ceiling system is 97 % recyclable and therefore manufactured almost entirely from recoverable materials, making disposal particularly environmentally friendly. By ensuring proper disposal of decommissioned components, you not only conserve natural resources but also support the circular economy.

If you have any questions regarding recycling our products, we will be pleased to assist.

	ENVIRONMENTAL PROTECTION
Proper disposal of products	
<ul style="list-style-type: none">▪ Separate the different materials, where possible, to facilitate the recycling process. Metal and plastic parts should be disposed of separately.▪ Take the separated materials to a local recycling center or appropriate collection point. These facilities specialize in properly processing recyclable materials.▪ Ensure compliance with applicable environmental regulations and disposal guidelines. This ensures environmentally friendly and legally compliant disposal.	

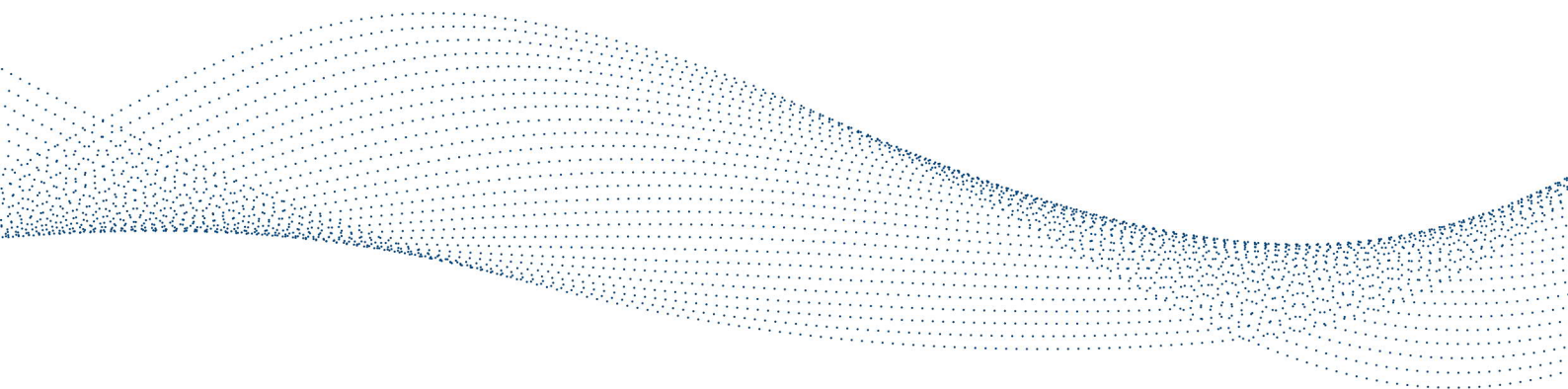

 **Durrer Technik AG**
 Winkelbüel 3, 6043 Adligenswil
 +41 41 375 00 11
 info@durrer-technik.ch
 www.durrer-technik.ch

Durrer Technik AG
Chemin de Préveyres 11, 1131 Tolochenaz VD
+41 22 354 80 80
romandie@durrer-technik.ch
www.durrer-technik.ch/fr

Durrer-technik